

PA-18 Safari Seat Installation Instructions

1. Remove existing seat back. Remove seat bottom springs. Refer to Piper PA-18 Parts Manual.
2. Spread clamps open to accept forward and rear seat bottom tubes – refer to note A on DWG No. 6152.
3. Trim wood/metal as necessary to accept clamps. i.e. under-seat storage box if installed.
4. With bushings on top, insert hardware and tighten finger tight (recommended that all bolts face aft).
5. Insert seat (centered in aircraft) and pin to clamps so that the clamp bushings are on the outboard side of the seat bushings. Check that seat back rest against rear seat cross bar.
6. Tighten bolts to a minimum of 30 inch pounds with seat pinned in place. Check seat operation for full functionality. For aircraft hardware installation practices refer to AC43.13-1B chapter 4, section 3 and 4.
7. Seat must be restrained to rear seat cross bar during flight. Recommend Velcro straps – not included in kit.

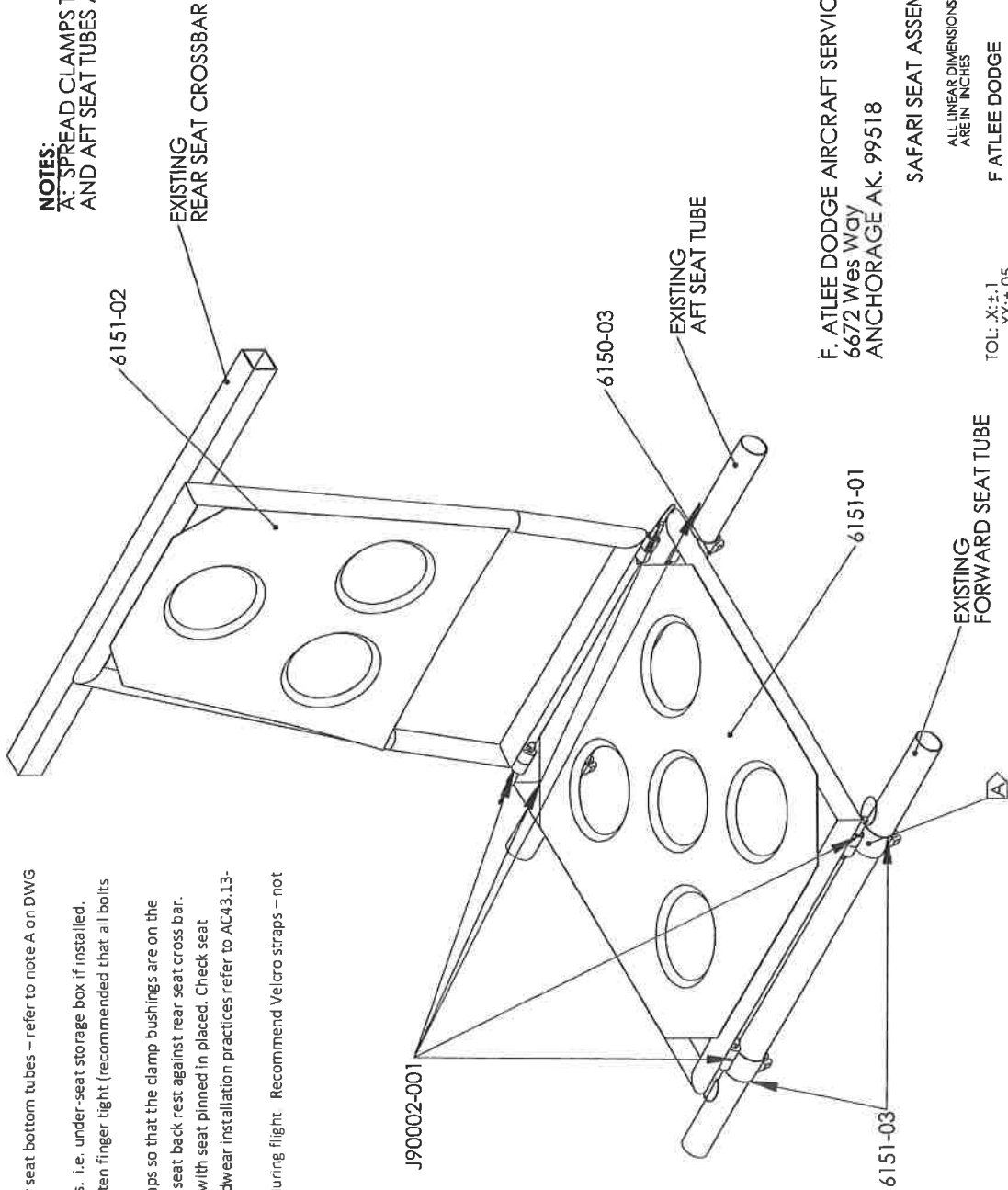

NOTES:
A: SPREAD CLAMPS TO FIT FORWARD AND AFT SEAT TUBES AS SHOWN

F. ATLEE DODGE AIRCRAFT SERVICES, LLC
 6672 Wes Way
 ANCHORAGE AK. 99518



SAFARI SEAT ASSEMBLY

ALL LINEAR DIMENSIONS ARE IN INCHES

SCALE: 1:4

F ATLEE DODGE
 Date: 5/27/09

CHG

TOL: X:±.1
 XX:±.05
 XXX:±.010

DWG: 6152

APPROV INT:
 SHEET: 1 OF 1

CHG	DATE	INITIAL	DESCRIPTION	GH	PP
-	1/25/09			BY	CHK

F. Atlee Dodge Aircraft Services, LLC
 (907) 344-1756 / Fax (907) 344-8720
 Atleedodge@acsaak.net

The drawings, specifications, Descriptions, and other critical data attached hereto are property of F. Atlee Dodge Aircraft Services, LLC. No disclosures to others, within the United States of America or abroad, or reproduction of any part of the information supplied is to be released without written authorization from F. Atlee Dodge Aircraft Services, LLC.

F. Atlee Dodge Aircraft Services, LLC
APPROVED FOR RELEASE
 By: *[Signature]* 24. Aug. 09

F. Atlee Dodge Aircraft Services, LLC.
Anchorage, AK

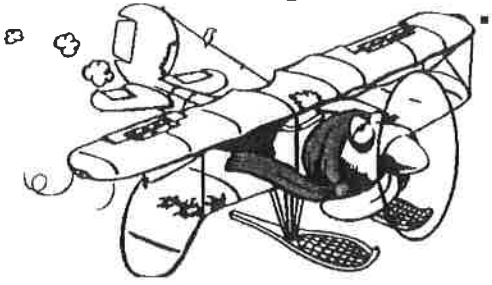

F. Atlee Dodge Aircraft Services, LLC.

6672 Wes Way * Anchorage, Alaska 99518

Phone: (907) 344-1755 * Fax: (907) 344-6720

atleedodge@acsalaska.net ~ www.fadodge.com

INSTRUCTIONS FOR CONTINUED AIRWORTHINESS

Safari Seat
Piper PA18 Series Aircraft

RETAIN THIS DOCUMENT WITH THE AIRCRAFT RECORDS

Document Number: ICA-1018

REVISION HISTORY

Revision	Description	Date
IR	Initial Release (IR) for AEG Review.	07-14-2009

ltd

For updated revisions of this document it is the owner/operators responsibility to contact F. Atlee Dodge Aircraft Services, LLC. through our website or directly at the numbers given above.

**This document meets the requirements of 14 CFR 23.1529 (Appendix G).
Additionally it is found acceptable to the FAA AEG in accordance with the guidelines outlined in FAA Order 8110.54.**

Information contained herein is the property of F. Atlee Dodge Aircraft Services, LLC. <i>Copy or reproduction, manual or electronic, is not authorized without prior written consent.</i>	Doc. No.:	1018
	Revision:	IR
	Date:	July 14 .2009
	Page	1 of 6

TABLE OF CONTENTS

1 Model Applicability3
2 Modification Description.....4
 2.1 Illustrated Parts4
 2.2 Parts List5
3 Installation and Removal Procedures5
 3.1 Installation5
 3.2 Removal5
4 Maintenance.....6
 4.1 Inspection Requirement6
5 Airworthiness Limitations6

<p>Information contained herein is the property of F. Atlee Dodge Aircraft Services, LLC. <i>Copy or reproduction, manual or electronic, is not authorized without prior written consent.</i></p>	Doc. No.:	1018
	Revision:	IR
	Date:	July 14 .2009
	Page	2 of 6

1 Model Applicability

The data presented in this Instruction for Continued Airworthiness (ICA) is intended to augment the information contained in the original aircraft maintenance manual or structural repair manual. Additional information on recommended best practices and acceptable methods, techniques can be obtained from a current version of FAA Advisory Circular (AC) 43.13-1B/2A.

Make/Model	TCDS	Certification Basis (per TCDS)	Comments
Piper PA-18, PA-18S, PA-18 "105" (Special), PA-18S "105"(Special), PA-18A, PA- 18 "125" ..(Army L-21A), ..PA-18AS "125", PA-18S "125", PA-18 "135" (Army L-21B), PA-18A "135", PA- 18S "135", PA-18AS "135", PA-18 "150", PA-18A "150", PA-18S "150, PA-18AS "150", PA-19 (Army L-18C), PA-19S	A-799	CAR 3, 11/1/49, 3-1	

Information contained herein is the property of F. Atlee Dodge Aircraft Services, LLC. Copy or reproduction, manual or electronic, is not authorized without prior written consent.	Doc. No.:	1018
	Revision:	IR
	Date:	July 14 .2009
	Page	3 of 6

2 Modification Description

NOTE:

The rear seat installation does not include an approved seat belt. It is the owner/operators responsibility to obtain and install an appropriately rated seat belt.

This modification consists of removal of the original rear seat and installing Rear folding "Safari" Seat. The safari seat will bolt onto existing fuselage tubes with a specially made seat clamp weldment (6151-03) at each of the four seat corners. Once these clamps are installed the seat back, bottom or both can be removed by pulling the J90002-001 Pins.

The seat back (6151-02) must be secured to the *rear cross bar* in flight. It is suggested that a Velcro strap be used.

2.1 Illustrated Parts

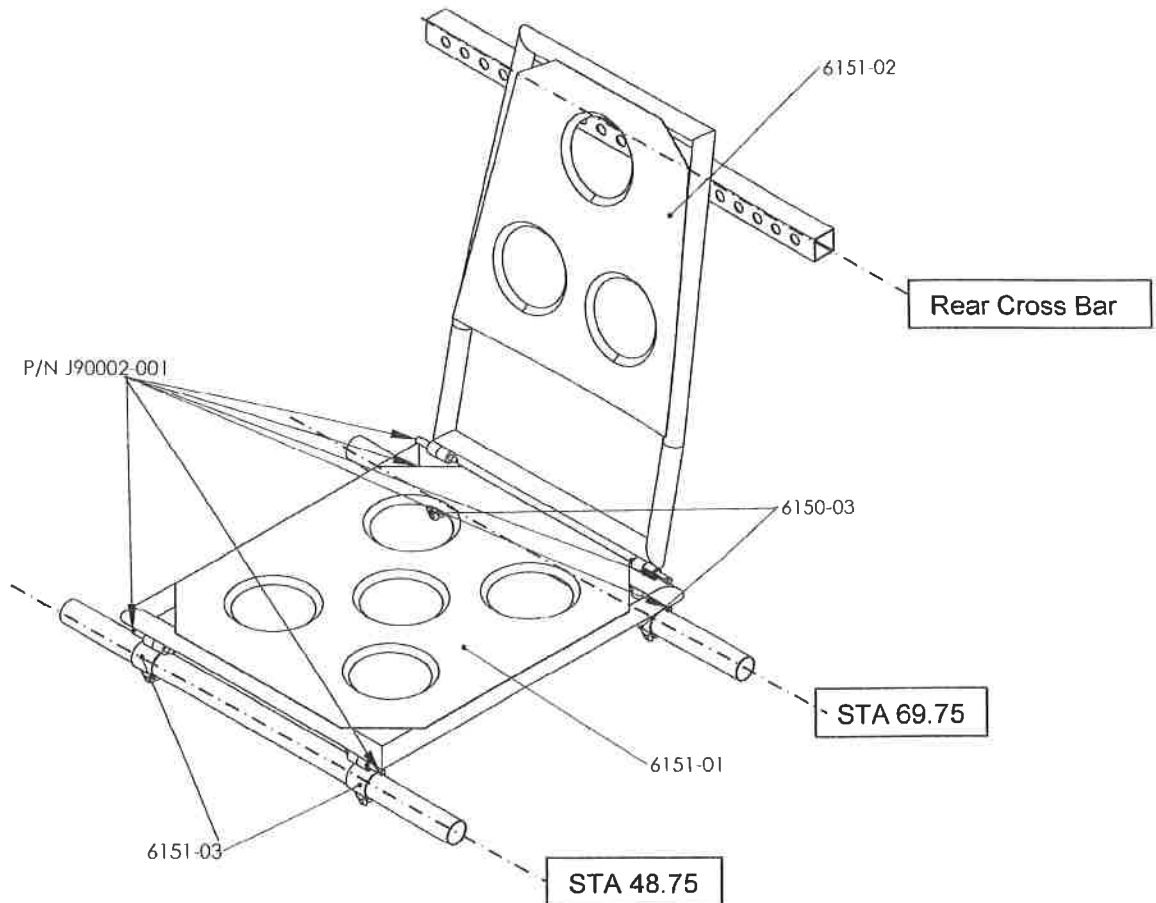

Information contained herein is the property of F. Atlee Dodge Aircraft Services, LLC. <i>Copy or reproduction, manual or electronic, is not authorized without prior written consent.</i>	Doc. No.:	1018
	Revision:	IR
	Date:	July 14 .2009
	Page	4 of 6

2.2 Parts List

Part Description	Part Number	Quantity	Comments
Seat Back	6151-02	1	FAA/PMA'd
Seat Bottom	6151-01	1	FAA/PMA'd
Clamps	6151-03	4	FAA/PMA'd
Pins	J90002-001	6	Supplied in kit
AN4-7A	Bolts	4	Supplied in kit
MS21044N4	Nut	4	Supplied in kit
AN960-416L	Washers	8	Supplied in kit
Velcro Strap		18"	Local Purchase

3 Installation and Removal Procedures

NOTE:

These procedures are based on existing rear seat removed from aircraft.

3.1 Installation

1. Install P/N 6151-03 clamps on front (STA 48.75) and rear (STA 69.75) seat tubes. DO not tighten at this time.
2. Position seat bottom P/N 6151-01 on clamps using 4 pins P/N J90002-001. Center seat on tubes.
3. Tighten clamp to 30 in-lbs torque.
4. Install seat back P/N 6151-02 using pins P/N. J90002-001 on lower tube of seat back. Secure top of seat back to rear seat upper cross bar with velcro straps.

3.2 Removal

1. Take out seat back by removal of pins (2x). Store with seat back.
2. Take out seat bottom by removal of pins (2x). Store with seat bottom.
3. Remove clamps as by removing AN4 bolts. Store with seat bottom.

Information contained herein is the property of F. Atlee Dodge Aircraft Services, LLC. Copy or reproduction, manual or electronic, is not authorized without prior written consent.	Doc. No.:	1018
	Revision:	IR
	Date:	July 14 .2009
	Page	5 of 6

F. Atlee Dodge Aircraft Services, LLC.
Anchorage, AK

4 Maintenance

If repairs are required to seat back, bottom or clamps, contact F. Atlee Dodge Aircraft Services, LLC. by telephone at 907-344-1755.

4.1 Inspection Requirement

The seat back, bottom, clamps and fuselage tubes should be inspected, for wear, damage or deformation on a 100HR/annual or progressive basis in accordance with the applicable maintenance manual and replace hardware as required.

5 Airworthiness Limitations

This Airworthiness Limitations Section is FAA approved and specifies maintenance required under paragraphs 43.16 and 91.403 if the Federal Aviation Regulations unless an alternate program as been FAA approved. This modification does not affect the airworthiness section of the FAA Approved Maintenance Manual.

No additional airworthiness limitations have been imposed by this modification.

END

Information contained herein is the property of F. Atlee Dodge Aircraft Services, LLC. <i>Copy or reproduction, manual or electronic, is not authorized without prior written consent.</i>	Doc. No.:	1018
	Revision:	IR
	Date:	July 14 .2009
	Page	6 of 6