



F. Atlee Dodge Aircraft Services, LLC

6672 Wes Way * Anchorage, Alaska 99518

Phone: (907) 344-1755 * Fax: (907) 344-6720

atleedodge@acsalaska.net ~ www.fadodge.com

INSTALLATION INSTRUCTIONS (II)

for installation of

F. Atlee Dodge Landing Gear Fueling Step On

Applicable Piper Aircraft

Document Number: II-3190

REVISION HISTORY

Revision	Description	Date
-	Initial Release (IR)	05 Dec 2016
A	Added dash (-) numbers to differentiate clamp diameters.	25June2018

For updated revisions of this document it is the owner/operators responsibility to contact F. Atlee Dodge Aircraft Services, LLC. through our website or directly at the numbers given above.

1 Introduction

This Installation Instruction (II) is intended to augment the information contained in the original aircraft maintenance manual or structural repair manual. Refer to AC 43.13-1B/2B for acceptable methods, techniques, and practices for inspection, repair, and alteration when there are no manufacturer repair or maintenance instructions.

1.1 Model Applicability

This document is applicable to the Makes and Models outlined in the associated Approved Model List (AML) for this STC.

2 Modification Description

This modification adds a fueling step to the outside of the front strut of the main landing gear.

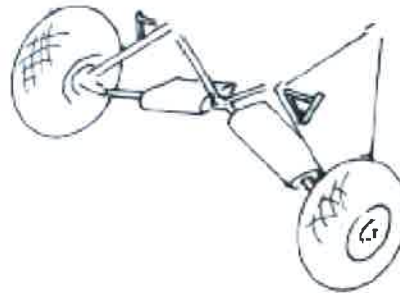

3 Installation

This installation is applicable to both the single bracket [P/N 3190-(X)] and larger double bracket (P/N 3190-12-SKI) steps. Prior to installation of the fueling step, it is assumed that the step(s) and landing gear are in an airworthy configuration. P/N 3190-10 steps fit 1 1/4" diameter landing gear tubes. P/N 3190-11 steps fit 1 3/8" diameter landing gear tubes. P/N 3190-12 steps fit 1 1/2" diameter landing gear tubes. P/N 3190-12-SKI steps fit 1 1/2" diameter landing gear tubes.

INSTALLATION INSTRUCTIONS:

1. The step is to be located on the outside of the front strut of the main landing gear. Position the step so the clamp is just below the cap and the clamp seats evenly on the strut.

Note: If gear is fabric covered, after positioning the step, mark fabric and remove only enough fabric to enable the step to seat evenly and allow the clamp and hardware to be installed. Make fabric repairs per AC 43.13-1, section 3.

2. It may be necessary to bend the brake line away from the strut to make clearance to install the clamp half. Exercise care not to kink the brake line (Refer to AC43.13-1A, page 170, Min. Bend Radius to Tubing).

907-344-1755

E Mail atleedodge@acsalaska.net

www.fadodge.com

3. Install attachment hardware per inset below for the clamp used. (INSET 1 for P/N 3190-(X) or INSET 2 for P/N 3190-12-SKI). Torque to 100 in.-lbs. Torque should be checked whenever any looseness is noted.
4. Make sure step will not rotate with the weight of a 250 lb. person.
5. Fill out FAA Form 337 and make log book entry.

INSET 1: Single bracket step:

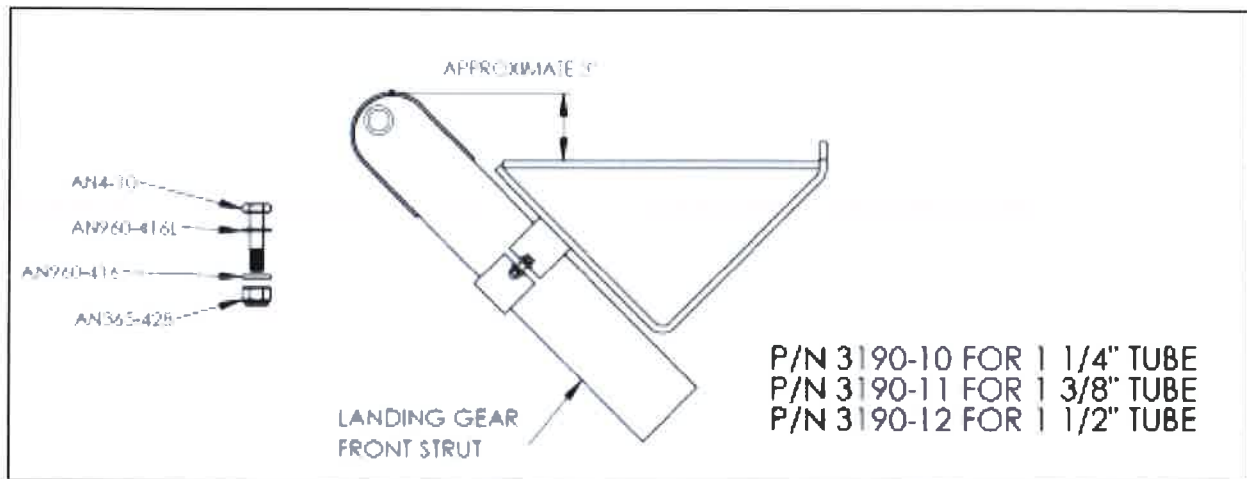

INSET 2: Larger double bracket step:

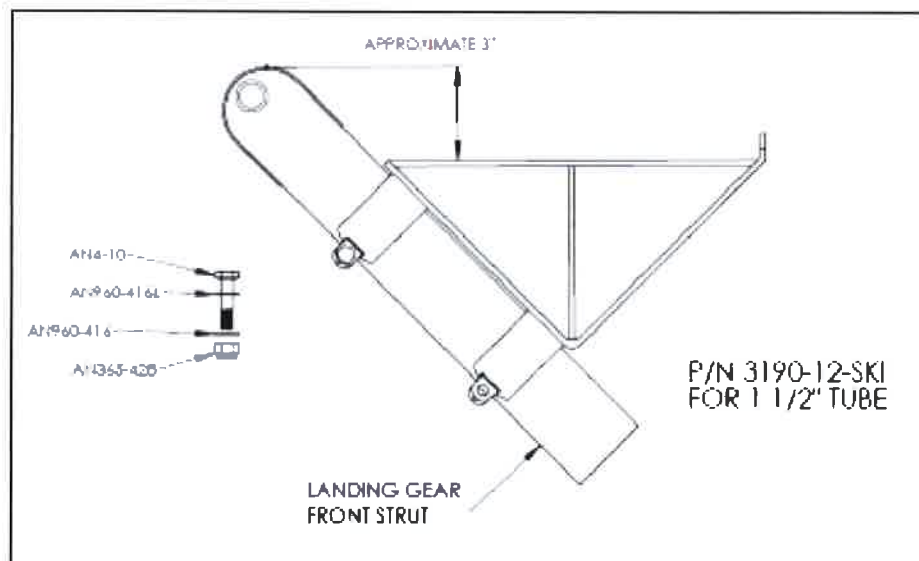

907-344-1755

E Mail atleedodge@acsalaska.net

www.fadodge.com

Weight & Balance

Weight and Balance difference is negligible.

907-344-1755

**E Mail atleedodge@acsalaska.net
www.fadodge.com**